

THIS IS A C.A.D. GENERATED DRAWING
DO NOT MAKE MANUAL REVISIONS TO MASTER.

* UNLESS OTHERWISE SPECIFIED TOLERANCES
ON DECIMAL IS: ANGLE
UNIT: MM X.
X.X

ISSUE NUMBER

ORIGINAL ①

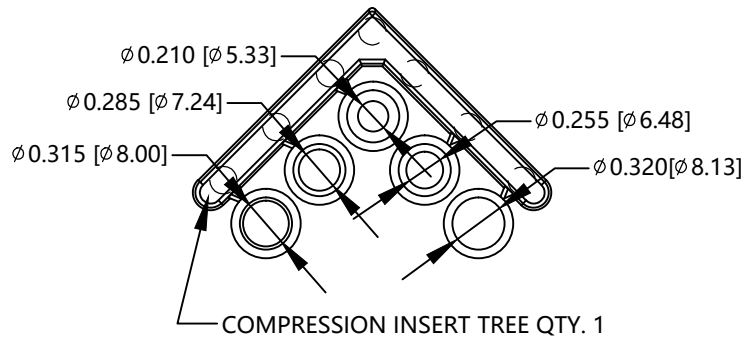
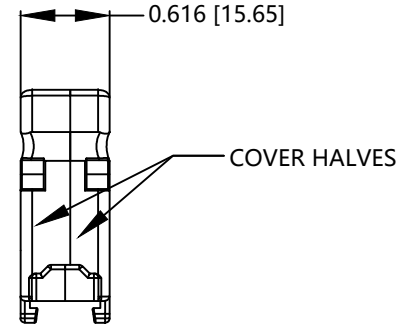
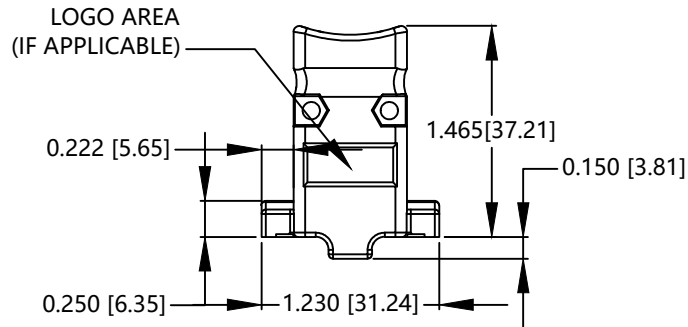
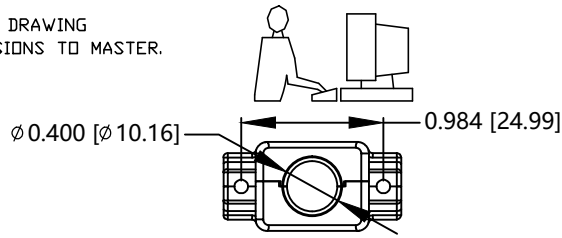

#4-40 X 7/16" FILLISTER HEAD MACHINE SCREW
MATERIAL - STEEL
FINISH - BRIGHT ZINC
QTY: 2 EACH



#4-40 #2 BLANK HEX NUT
MATERIAL - STEEL
FINISH - BRIGHT ZINC
QTY: 2 EACH



FILLISTER HEAD CAPTIVE SCREW
HEAD STYLE - SEE PAGE 2
MATERIAL - SEE PAGE 2
FINISH - SEE PAGE 2
QTY: 2 EACH



#4 SADDLE WASHER
MATERIAL - STEEL
FINISH - BRIGHT ZINC
QTY: 2 EACH



CONNECTOR COVER:
1. MATERIAL : ZINC ALLOY
2. FINISH : BRIGHT ZINC PLATING PER NTC SPECIFICATION N/T 000100
3. DIMENSIONS : INCHES [MM]
4. TOLERANCE : ±0.015 [0.381]

COMPRESSION INSERT TREE
1. MATERIAL : THERMOPLASTIC
2. COLOR : BLACK
3. DUROMETER : 75±5 TYPE A PER ASTM D2240
4. DIMENSIONS : INCHES [MM]
5. TOLERANCE : ±0.020 [0.508]

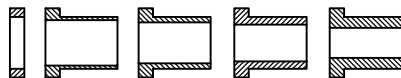

THESE DRAWINGS AND SPECIFICATIONS ARE THE PROPERTY OF MH CONNECTORS AND SHALL NOT BE REPRODUCED, COPIED OR USED AS THE BASIS FOR THE MANUFACTURE OR SALE OF APPARATUS WITHOUT WRITTEN PERMISSION.

DRAWN Henry Pan	DATE 2023/02/28
--------------------	--------------------

APPROVED	DATE
----------	------

SCALE 1:1	SHEET OF 1 OF 2	REV: 1
--------------	--------------------	-----------

DRAWING No
MHC88E000209



THIS SERIES FULLY CONFORMS TO THE EUROPEAN UNION DIRECTIVES 2015/863/EU AND 2011/65/EU FOR RoHS COMPLIANCY.



MH CONNECTORS,
DIVISION OF EDAC